

# SUPER-G™ WITH TUNGSTEN

## SECONDARY CONVEYOR BELT CLEANING SYSTEM

The Super-G's unique "pass-through" mainframe design allows material to freely fall through it, keeping your systems online with little to no maintenance. This system is based on the same heavy duty mainframe and Perma-Torque tensioner as our Eraser system. The urethane cartridge holds the 6" tungsten-tipped blades, which allows the blades to flex with and maintain contact and pressure against the belt.

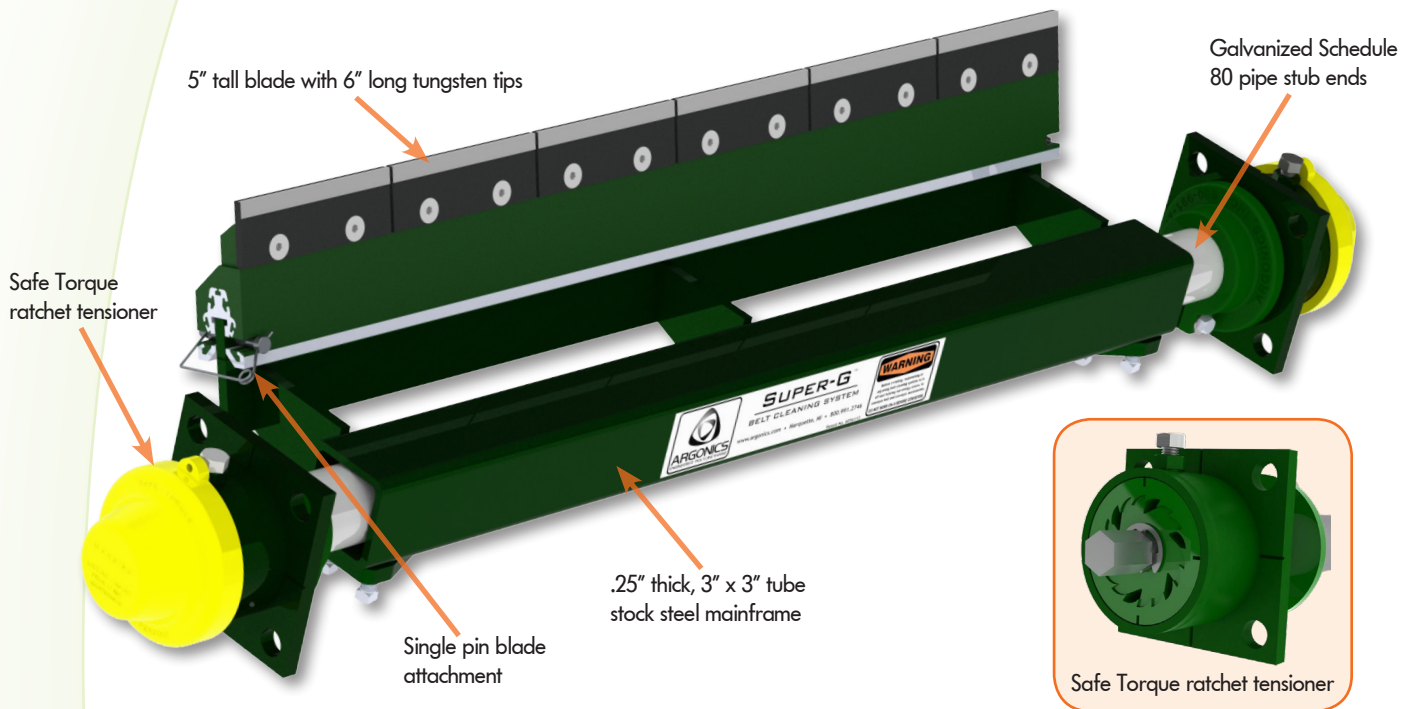

### BENEFITS

- Effective performance for wet, sticky secondary cleaning applications
- Solid urethane cleaning blades also available
- The Perma-Torque™ internal central tensioner is adjustable from 20 to 80 ft-lb (27 to 108 Nm) resulting in uniform cleaning pressure to the conveyor belt
- Compact mounting footprint only protrudes 5" (127 mm) from mounting structure
- Brightly colored safety yellow end caps seal the Safe Torque™ ratchet from dust and water contamination
- Single pin blade attachment means quick and simple blade change out

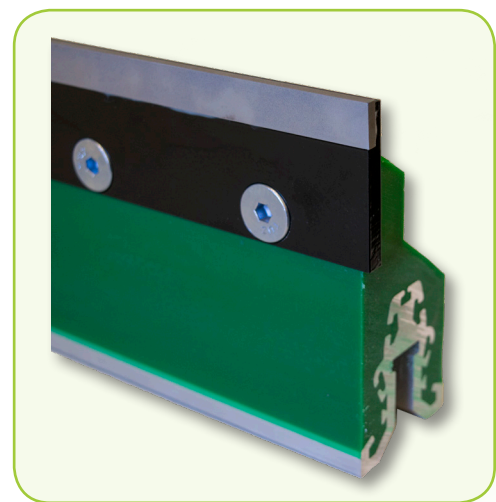

**ARGONICS**  
ENGINEERED POLYURETHANE

## SIZING INFORMATION

Dimensions - in. (mm)

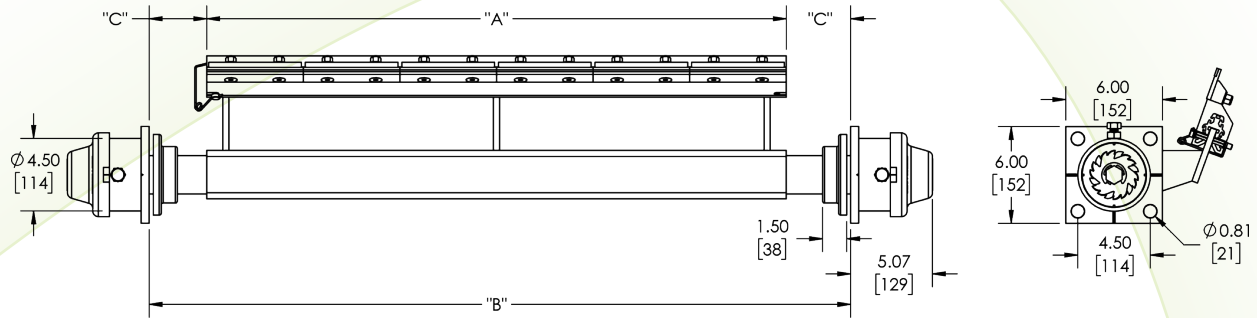

Part Number	A		Min B.	Max B.	Min C.		Max C.			
	inches	(mm)			inches	(mm)	inches	(mm)	inches	(mm)
CP-ESG2-18M-G83T	18.00	(457.2)	28.00	(711.2)	34.00	(836.6)	5.00	(127)	8.00	(203.2)
CP-ESG2-24M-G83T	24.00	(609.6)	28.00	(711.2)	40.00	(1,016)	2.00	(50.8)	8.00	(203.2)
CP-ESG2-30M-G83T	30.00	(762)	31.00	(787.4)	46.00	(1,168)	0.50	(12.7)	8.00	(203.2)
CP-ESG2-36D-G83T	36.00	(914.4)	37.00	(939.8)	52.00	(1,321)	0.50	(12.7)	8.00	(203.2)
CP-ESG2-42D-G83T	42.00	(1,067)	43.00	(1,092)	58.00	(1,743)	0.50	(12.7)	8.00	(203.2)
CP-ESG2-48D-G83T	48.00	(1,219)	49.00	(1,245)	64.00	(1,626)	0.50	(12.7)	8.00	(203.2)
CP-ESG2-54D-G83T	54.00	(1,372)	55.00	(1,397)	70.00	(1,778)	0.50	(12.7)	8.00	(203.2)
CP-ESG2-60D-G83T	60.00	(1,524)	61.00	(1,549)	76.00	(1,930)	0.50	(12.7)	8.00	(203.2)

### NOTES:

- To get minimum B or C, the locking collars must be removed.
- For extended tensioner, add 14" (356 mm) to B max. and 7" (178) to C max.

## SPECIFICATIONS

### Recommended Belt Speeds

Urethane Blade: 0 - 500 fpm (2.54 m/s)

Tungsten Blade: 0 - 1000 fpm (5.08 m/s)

### Mounting Distance

Vertical:  $7.5" \pm .25$  (190 mm  $\pm$  6)

Horizontal: up to 16" (406 mm)

## MOUNTING INFORMATION

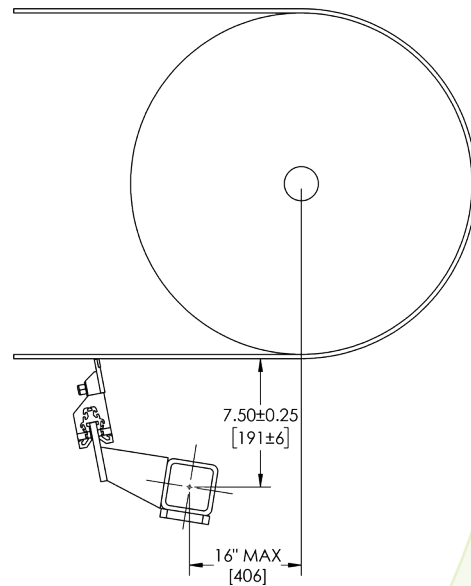

## NOMENCLATURE

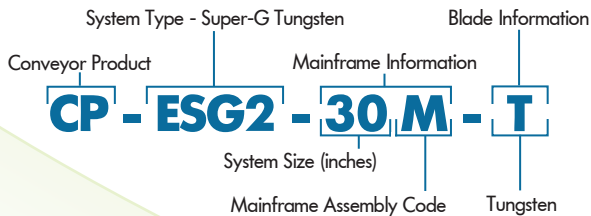

### Notes:

- Stainless steel systems are available. Contact your Argonics rep. for more information.
- System sizing of 6" (152 mm) under belt width is standard.



**ARGONICS**  
ENGINEERED POLYURETHANE



Jamieson Equipment Company  
www.jamiesonequipment.com  
toll free 800.875.0280